

# Hot Sedimentary Aquifer Heat in Scotland – the Guardbridge (Fife) Project

**Dr Ruth Robinson**

**Department of Earth & Environmental Sciences  
University of St Andrews**

**Phil Townsend (TRE Ltd), Paul Steen (Ramboll Energy), Hugh Barron, Rachael Ellen and  
Corinna Abesser (BGS), and Hugh Muschamp (Resource Efficient Solutions)**

**The GHURUS (Geothermal Heat Undergraduate Research Unit @ St Andrews)**

# Hot Sedimentary Aquifer Heat in Scotland – the Guardbridge (Fife) Project

## *FIFE GEOTHERMAL*

The GHURUS (Geothermal Heat Undergraduate Research Unit @ St Andrews)

# Geothermal energy projects awarded quarter million

14/06/2015 00:01

Scotland Agriculture Environment Housing Rural Development

Downloads

**Aberdeen Exhibition & Conference Centre among five schemes planning to harness Scotland's significant energy potential.**

- **Aberdeen Exhibition and Conference Centre:** to conduct a feasibility study for the installation of a deep geothermal single well system to provide heat to the new Centre and associated buildings
- **Guardbridge, Fife:** to explore the geothermal potential under a brownfield site to provide heat to on-site industries and the local community
- **Polkemmet, West Lothian:** to establish the feasibility of geothermal heat from mineworkings, which will heat proposed new social housing in the area
- **Hartwood, North Lanarkshire:** to develop a fully operational minewater geothermal district heating system which could act as an exemplar of how to transform farm economics and transfer benefits to local communities
- **Hill of Banchory, Aberdeenshire:** to explore the viability of adding geothermal energy from hot dry and hot wet rocks to the existing renewable heat network that is already serving the local communities

# Potential geothermal heat in central Scotland – why Guardbridge?

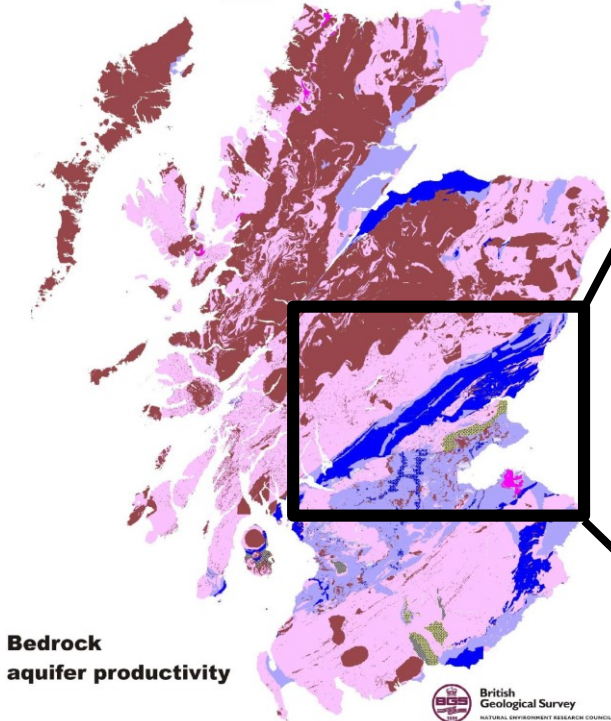
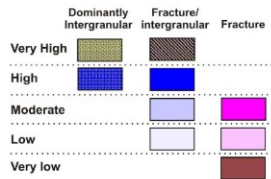

Bedrock aquifer productivity

British Geological Survey  
NATURAL ENVIRONMENT RESEARCH COUNCIL

Bedrock productivity map  
MacDonald et al. (2004)

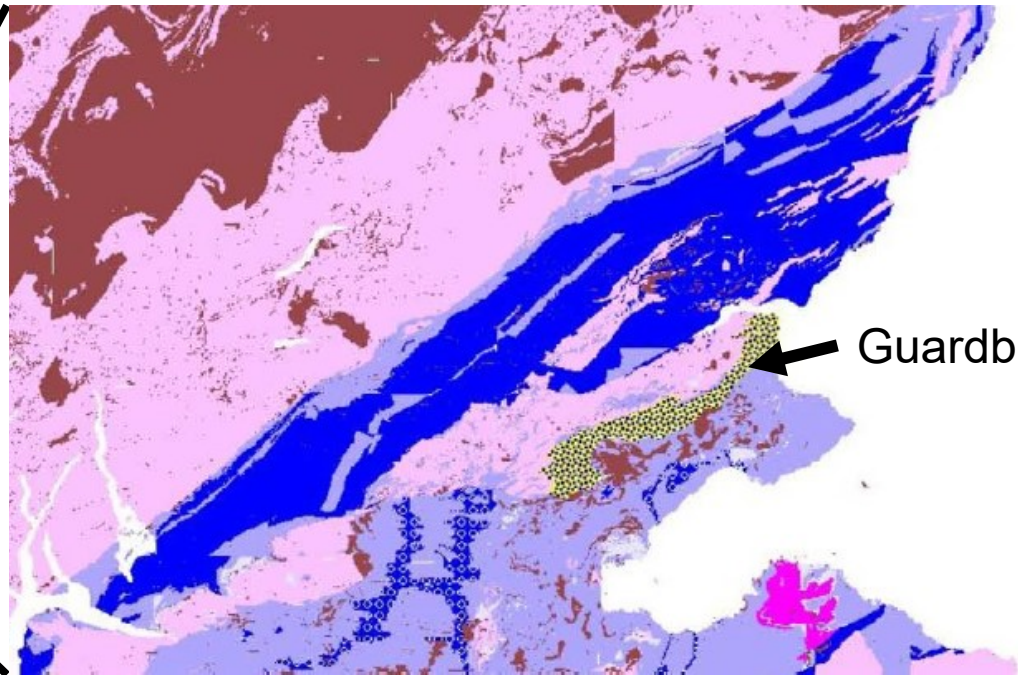

Guardbridge

Very productive intergranular aquifers  
around Guardbridge

# Regional significance of geothermal exploration at Guardbridge – sedimentary rocks are folded and reach depths of 4 - 5 km

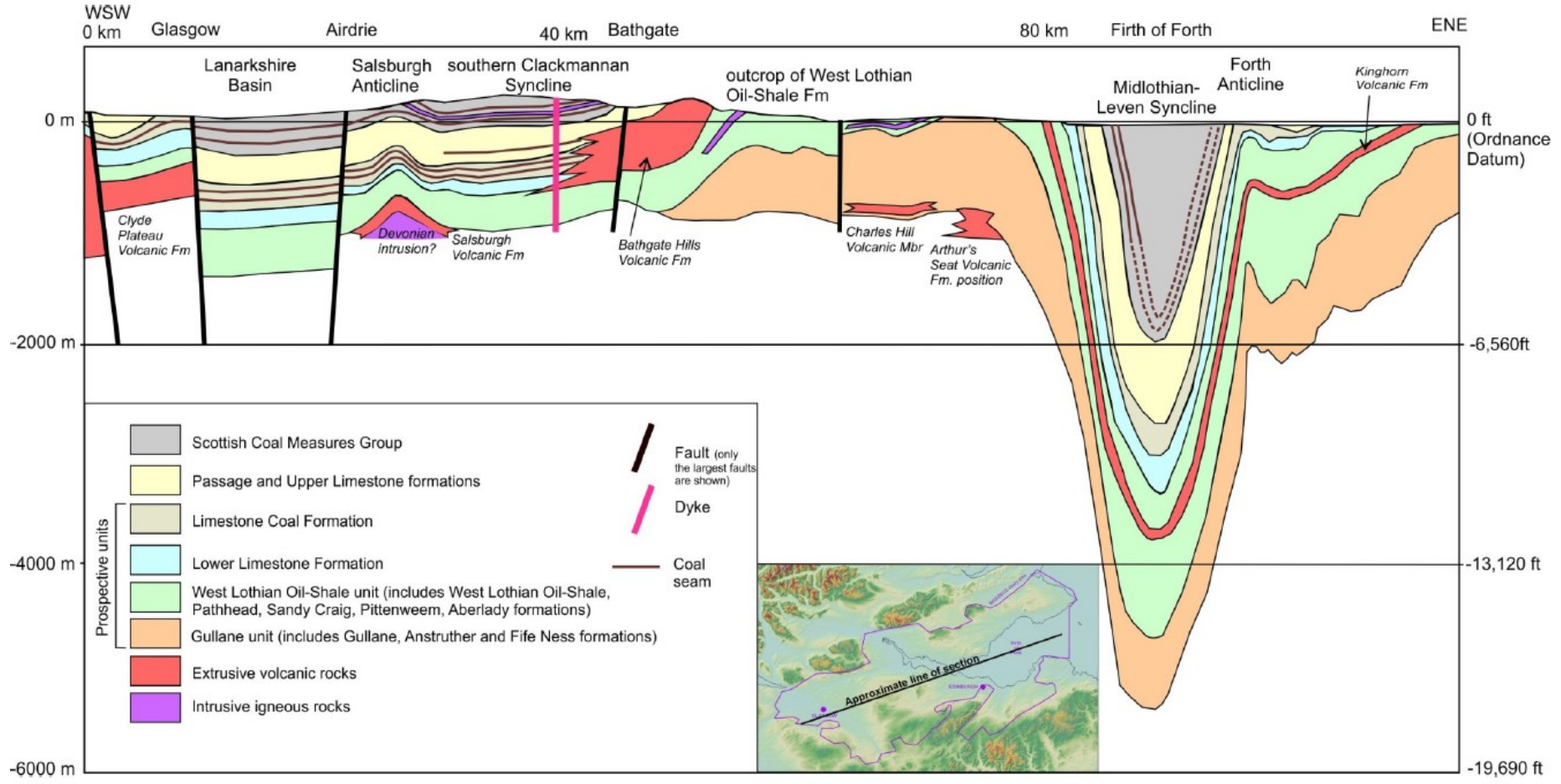

From Monaghan (2014)



# Hot saline aquifer targets are available in Fife near large towns

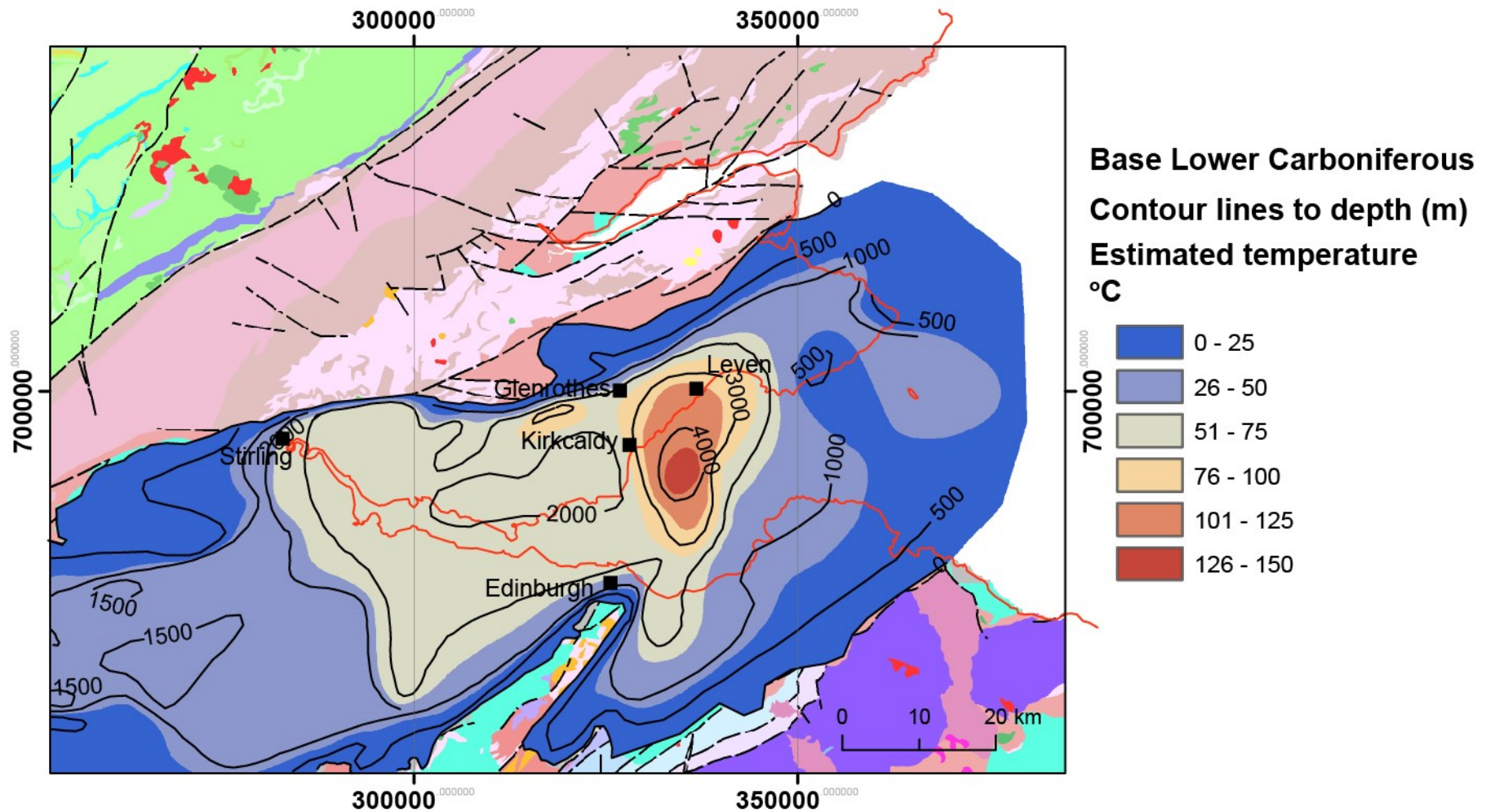

Background geology reproduced with the permission of the British Geological Survey ©NERC. All rights reserved.

Based on Browne et al.(1985)

# Guardbridge Geothermal Demonstrator Project - hot sedimentary aquifer

Is a geothermal well supplying heat to a district heating network economically feasible?



© Crown Copyright/database right 2016. An Ordnance Survey/EDINA supplied service

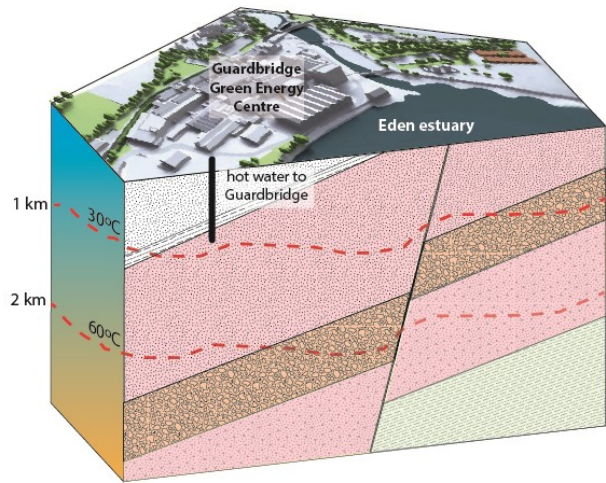

Guardbridge Low Carbon Energy Centre is site of 6.5 MW biomass plant (£25M funding). Heat to the University of St Andrews' buildings.



# Guardbridge geothermal feasibility project - the rocks!

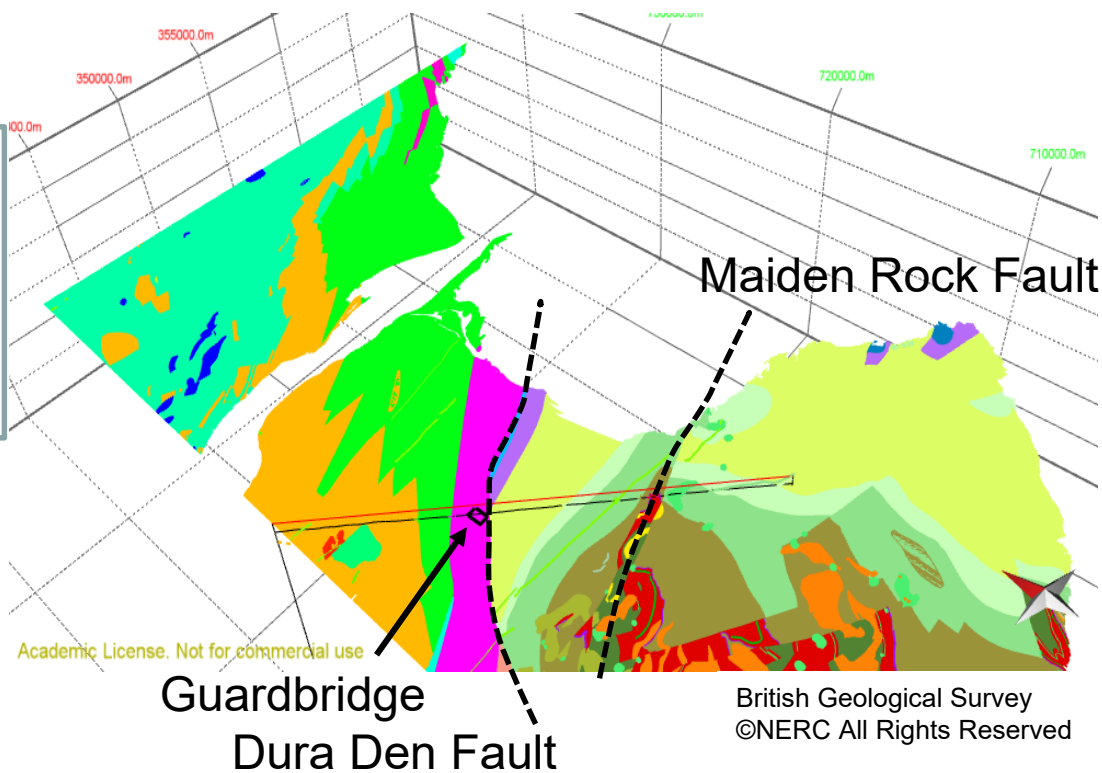
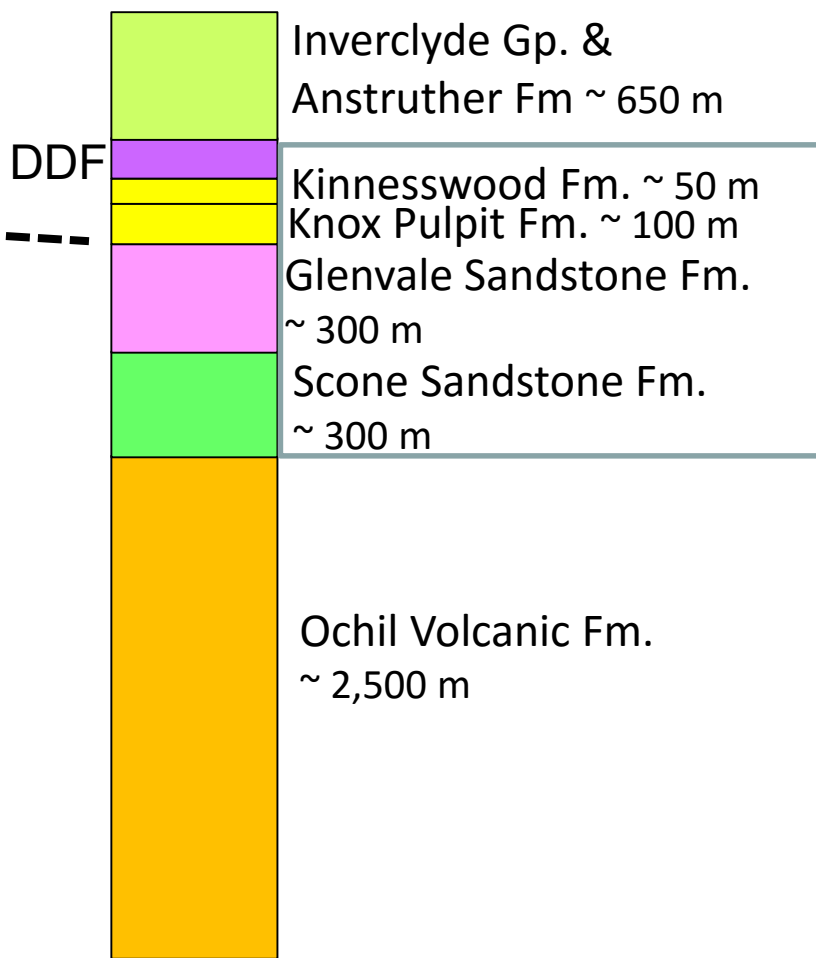

Lucy McKay (U St A) & Rachael Ellen (BGS)



# Knox Pulpit Fm Glenvale locality



Photo by Sarah Alexander (U St A)

# Local – regional geological model

## Results relevant to Midland Valley of Scotland

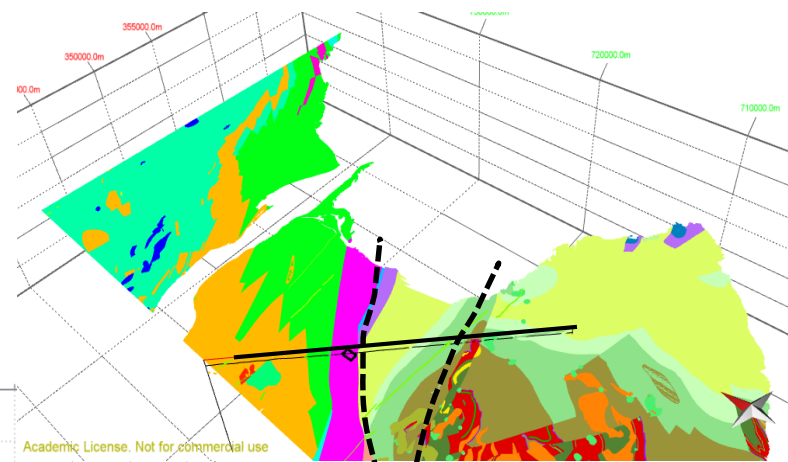

Guardbridge

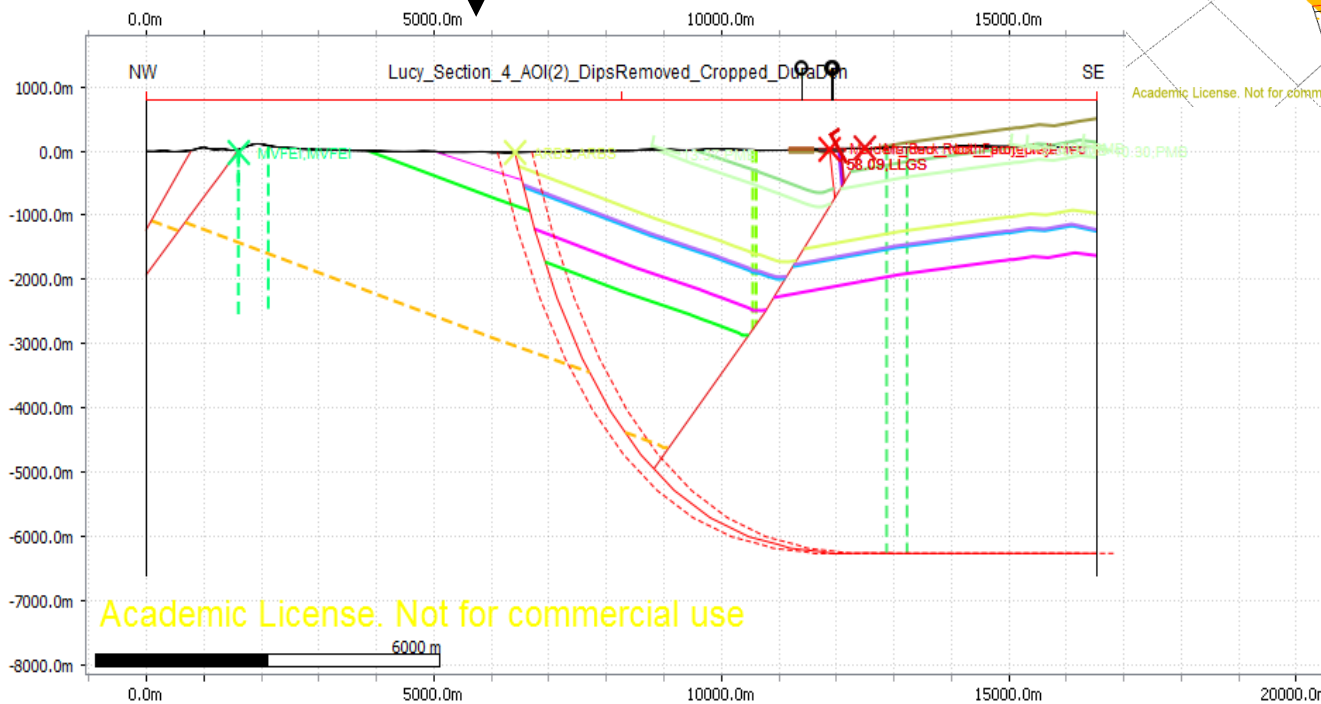

Academic License. Not for commercial use

- PDB
- SCB
- ARBS
- INV
- GFC
- Faults

- All available boreholes
- Some new BH coding
- Nothing deeper than 270 m
- Incorporation of existing BGS cross-sections
- McCoss (1987) for fault geometry



Lucy McKay (U St A; now Glasgow) & Rachael Ellen (BGS)





# Local – regional geological model

## Results relevant to Midland Valley of Scotland

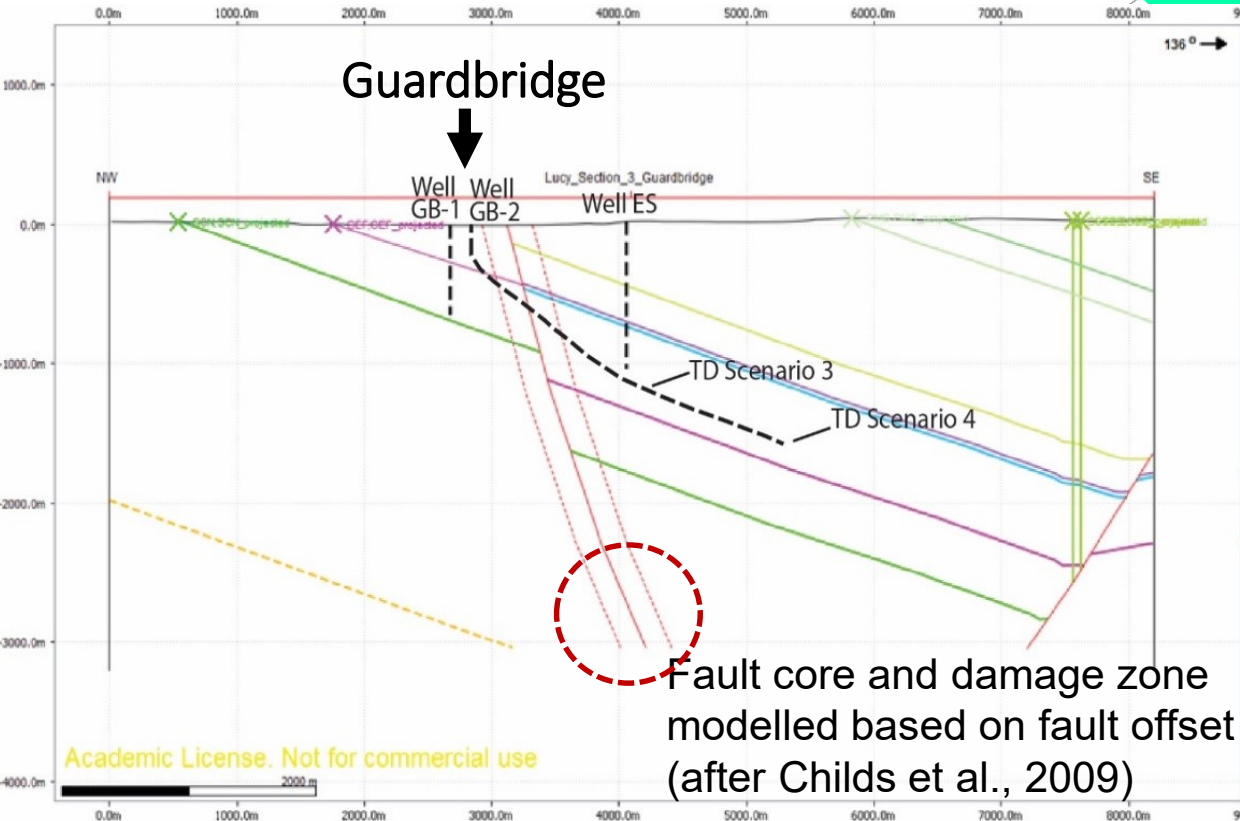
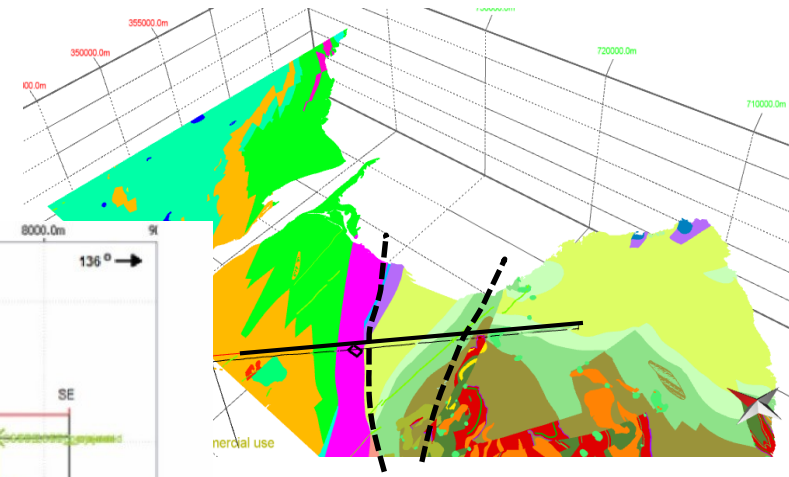

- 3 wells investigated
- GB-1 on site (Scone Ss.)
- ES-1 off site (Knox Pulpit)
- GB-2 deviated well (Knox Pulpit)



Lucy McKay (U St A; now Glasgow) & Rachael Ellen (BGS)





# Target aquifer properties: estimating porosity, permeability, and temperature

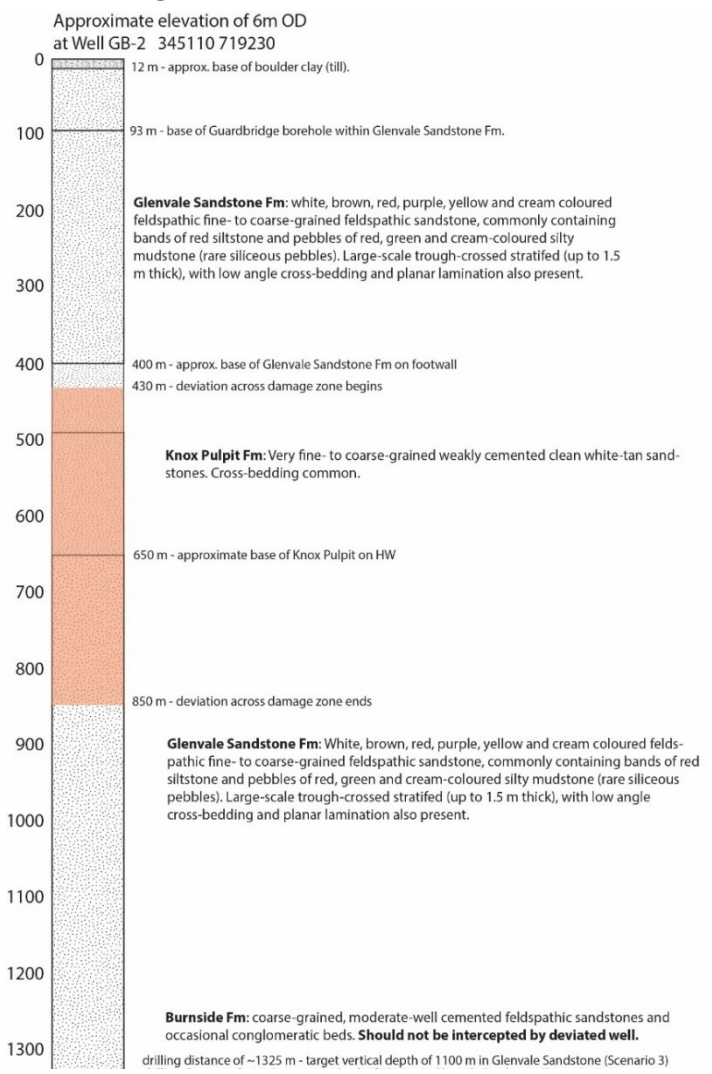
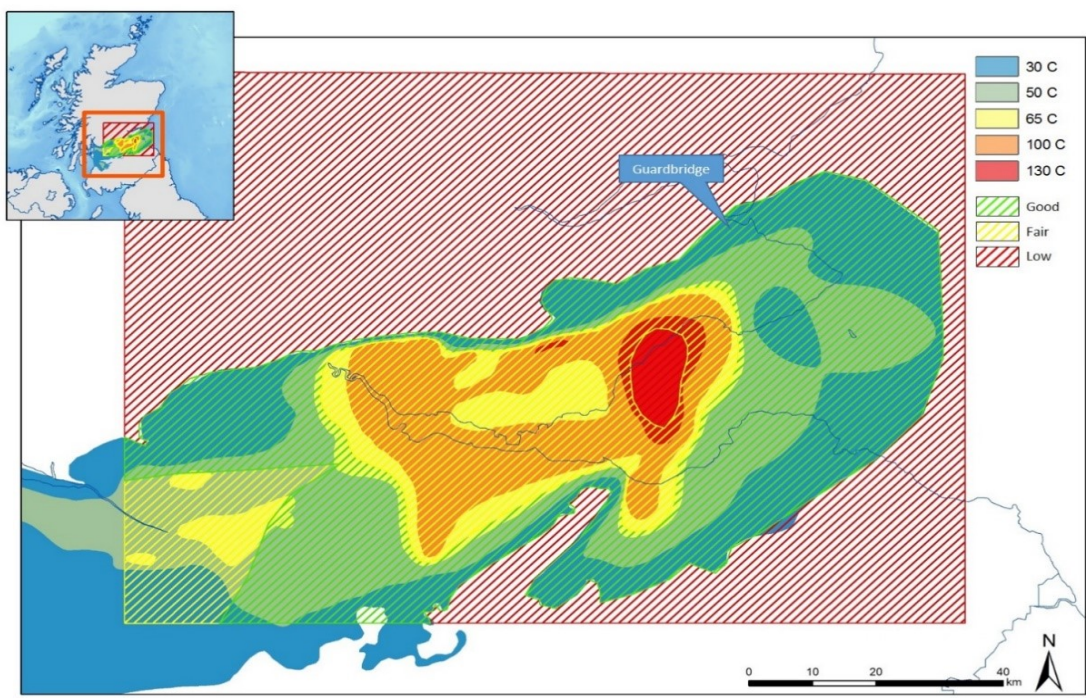

Combined map of estimated aquifer quality and predicted temperature.

Town Rock Energy with University of St Andrews.  
Wireline log data, new poroperm measurements, field work.

# Local hydrogeological model

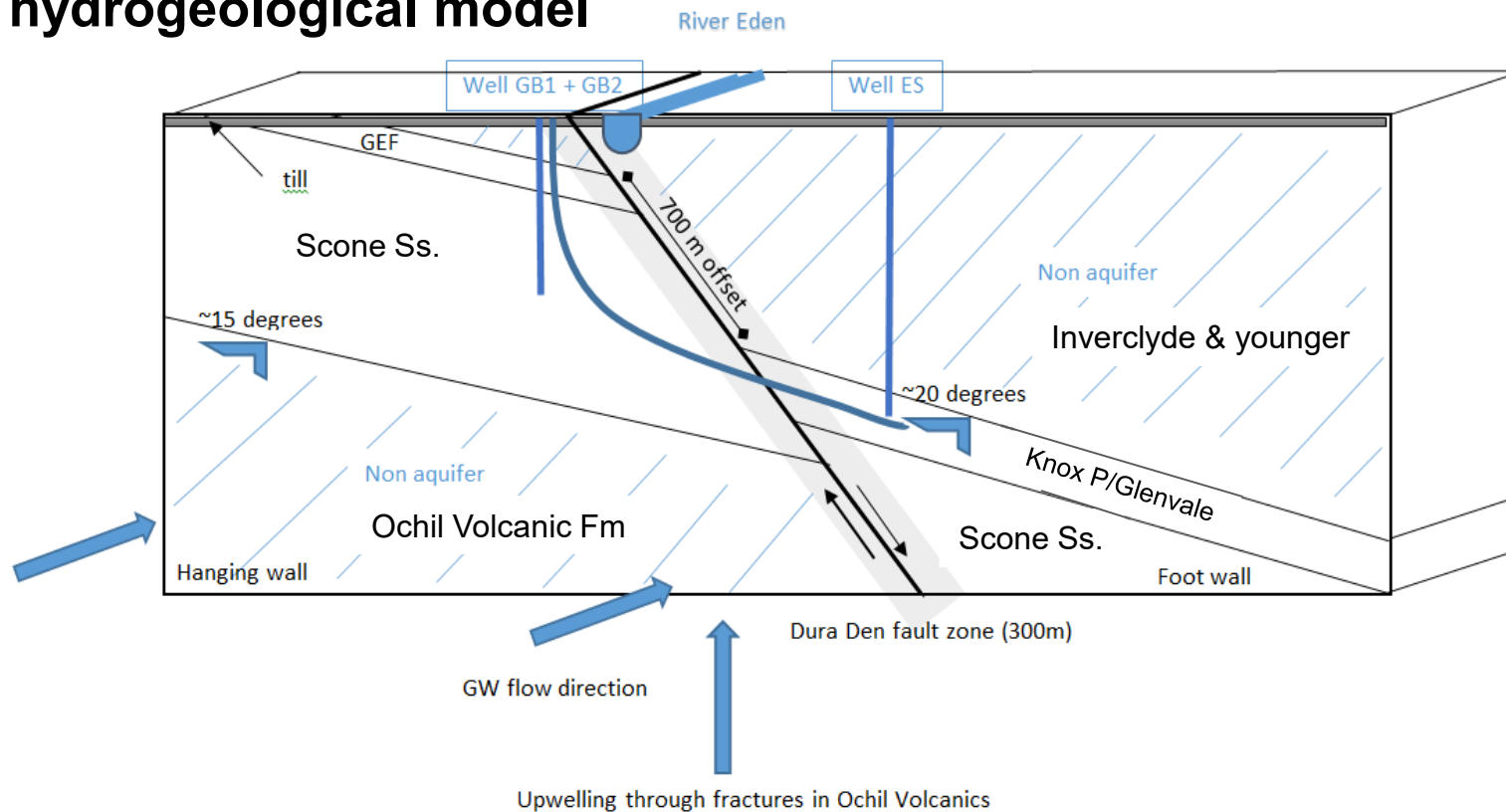

Conceptual hydrogeological model based on geological modelling:

*Build numerical model to test hydraulic conductivities (permeabilities) required for economic flow rates using finite element mass and heat transport model called FEFLOW.*



Sarah Alexander (U St A; now Birmingham) & Corinna Abesser (BGS)

A.

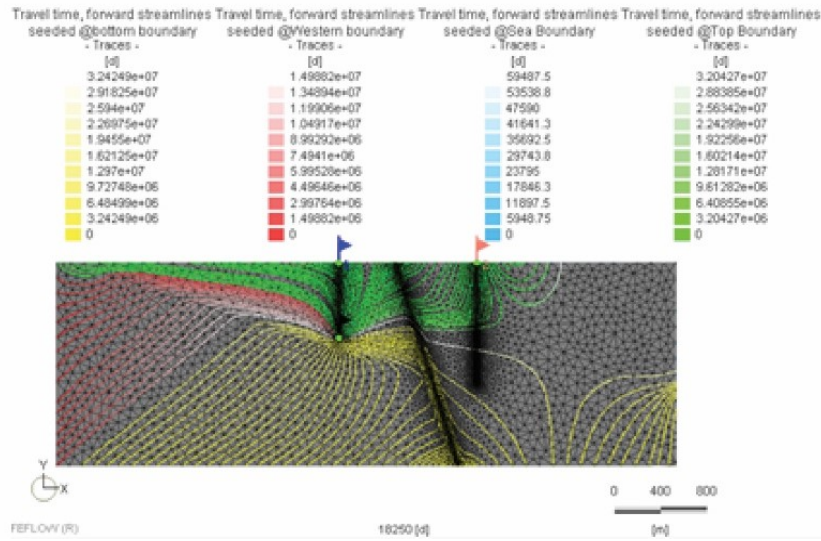

B.

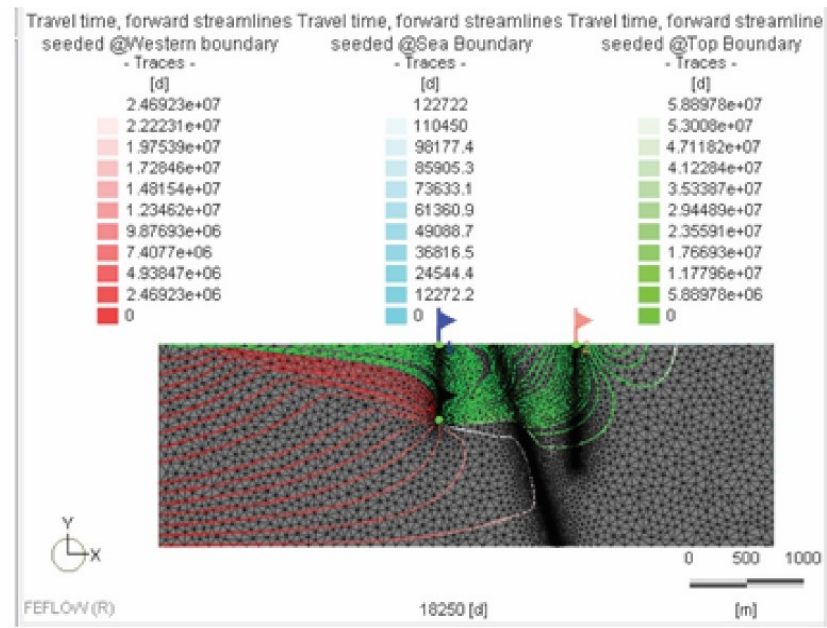

Increasing width of fault and hydraulic conductivity produces faster pathways:  
 Summary: A sustainable and economic aquifer (15 l/s) requires fracture permeability in rocks and fault zone.

C.

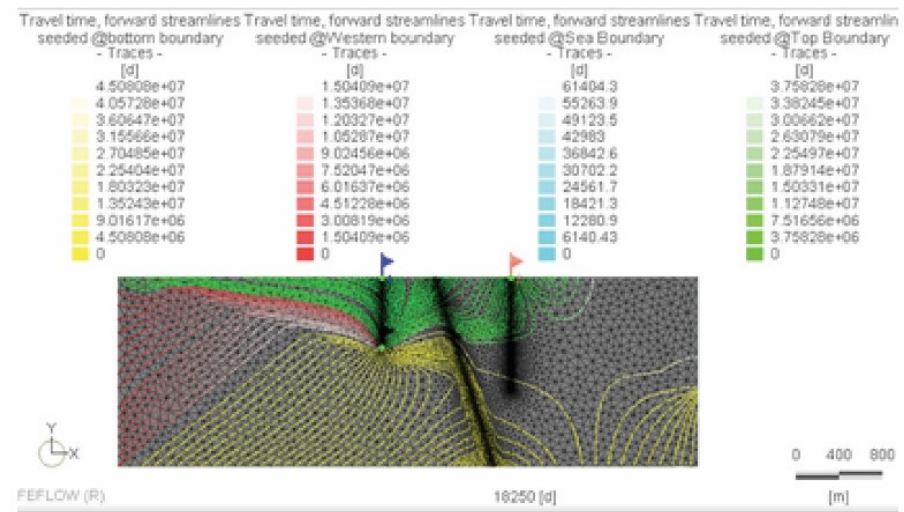

Sarah Alexander (U St A) & Corinna Abesser (BGS)





# Drilling strategy and options – oil and gas methodologies

Fluid Temperature - Tubing/Workstring

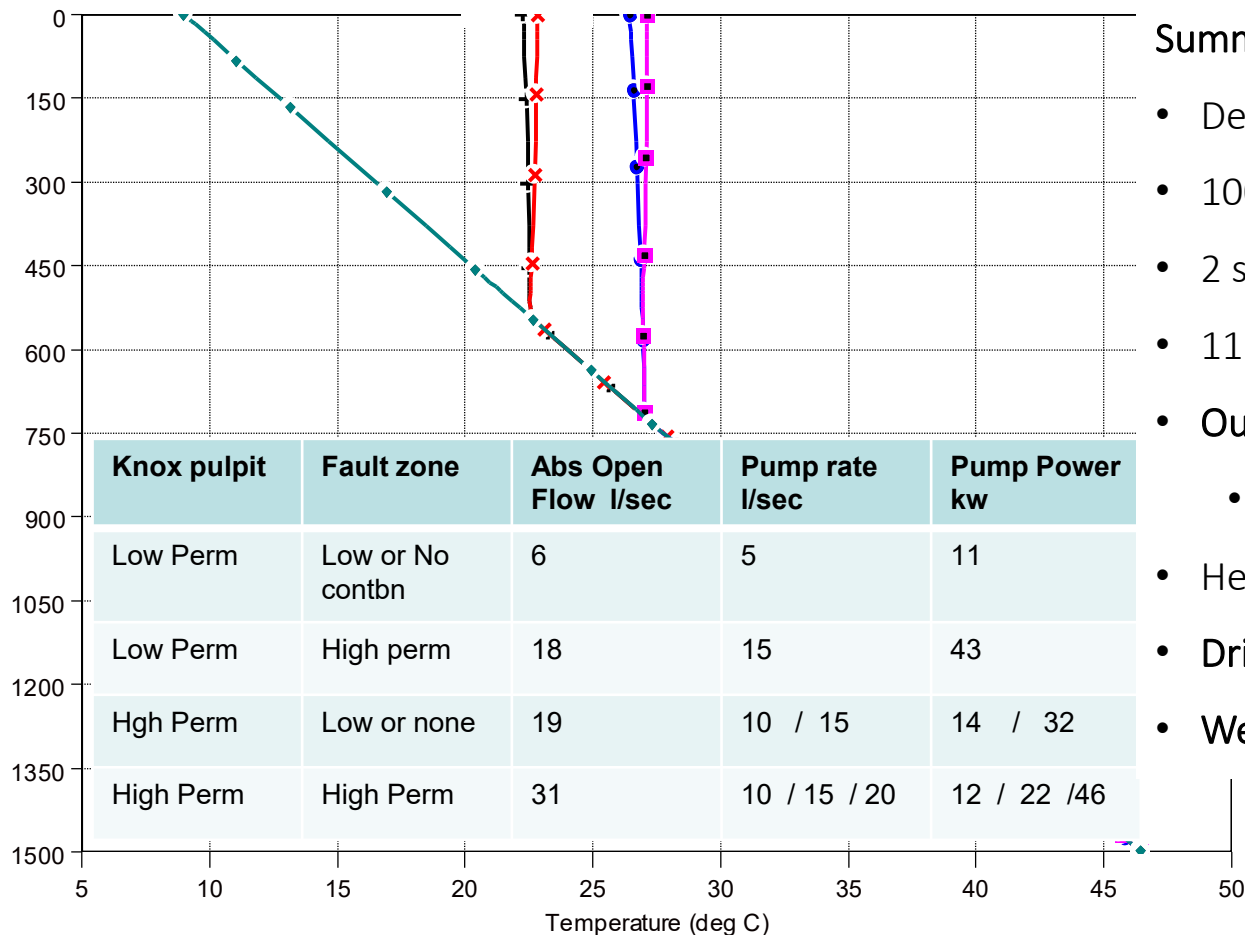

## Summary:

- Deviated well with submersible pump
- 1000 – 1200 metres well depth (TVD)
- 2 scenarios for flow rates – 5l/s & 15l/s
- 11 kw ESP or 22-43 kw pump required
- Output temperature of 23 – 27°C
  - 139 kW to 418 kW of heat output
- Heat pump delivering 75°C (COP = 4)
- Drilling costs - £750k - £1.1m (P90-P10)
- Well completion and flow tests - £150k

# Where is the heat demand?

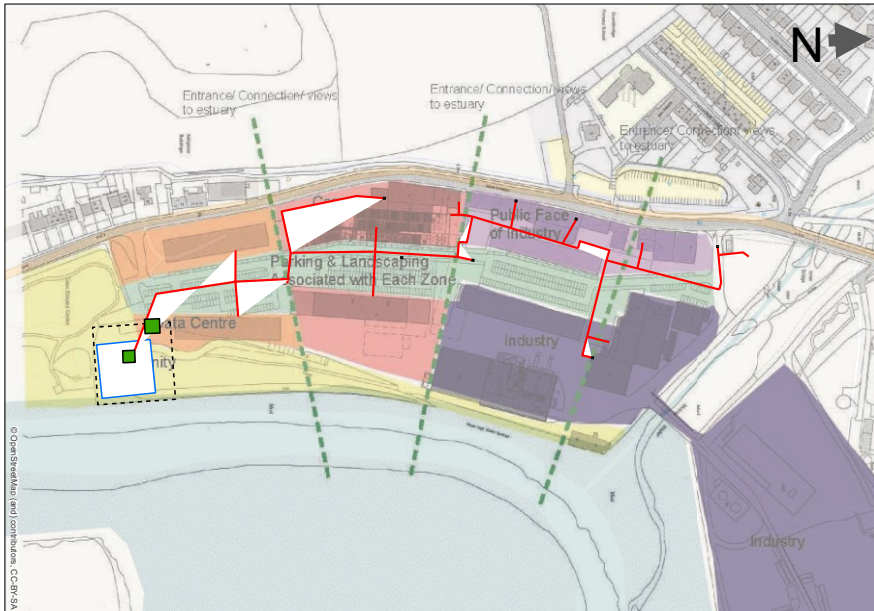
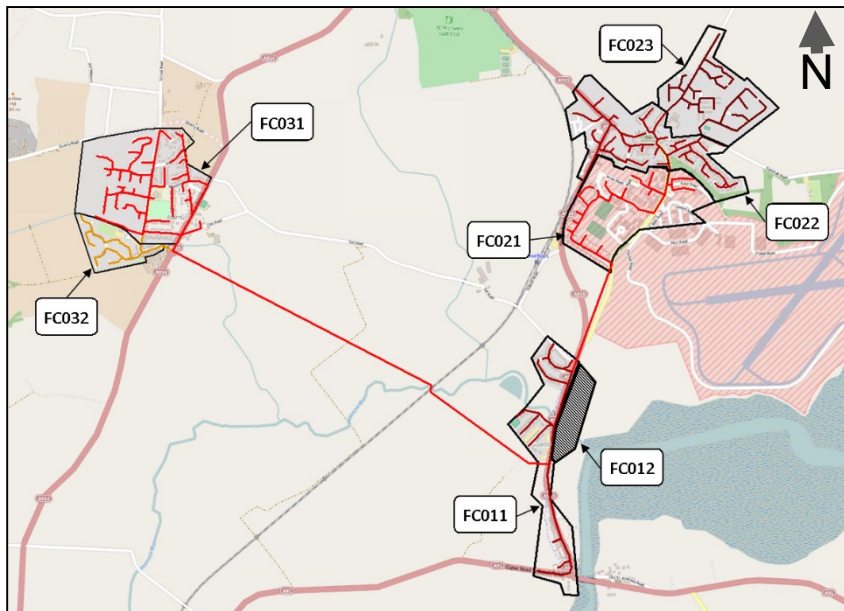

Potential district heat network for Guardbridge site, Guardbridge village, Leuchars and Balmullo.

Guardbridge site deemed economically feasible for the one well option.

DHN network design (red lines) for the proposed development at the Guardbridge Low Carbon Energy Centre.

Heat pump and DHN CAPEX - £530k  
Total CAPEX ~ £2.2M

# Energy centre design – integrated sources and combined heating/cooling

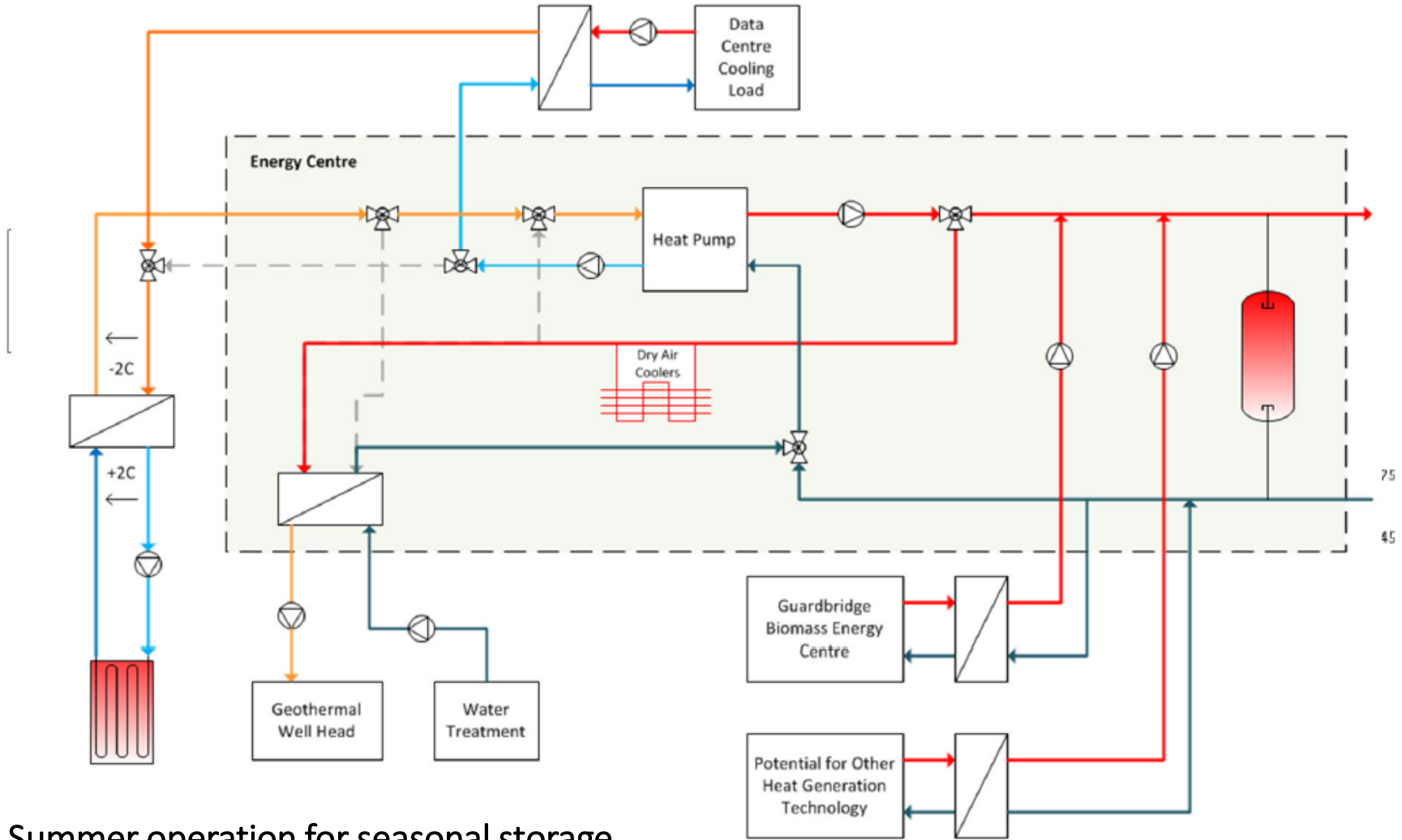

Summer operation for seasonal storage



# Carbon emissions reductions?

## Carbon emissions reductions from district heating compared to individual gas boilers

<b>20 Year Lifecycle Carbon Emissions Reduction</b>		
<b>Total CO<sub>2</sub> emission district heating</b>	4,677	Tonnes
<b>Total CO<sub>2</sub> emission baseline (gas boilers)</b>	28,574	Tonnes
<b>Saved CO<sub>2</sub> emission district heating compared to baseline</b>	23,987	Tonnes

- 84% reduction in emissions based on combined geothermal heat pumps and biomass plant

# LCITP Phase 2: Development Stage

## How do we start to reduce the risks associated with drilling?

- 1. Geophysical survey of the geothermal resource (moderately deep reflection seismic)
- 2. Review/revise well design and drilling CAPEX
- 3. Proceed to production or test borehole based on survey outcome

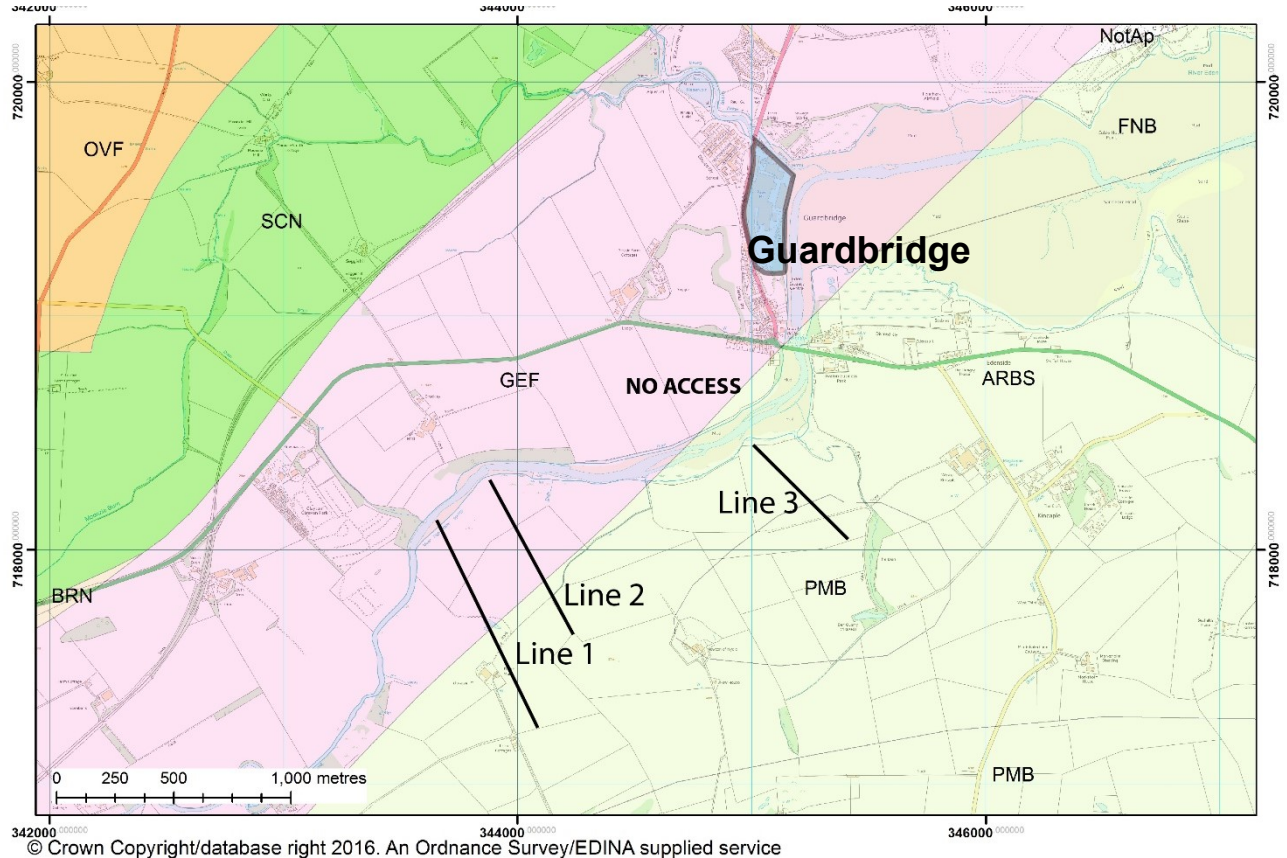

# LCITP Phase 2: Development Stage

## How do we start to reduce the risks associated with drilling?

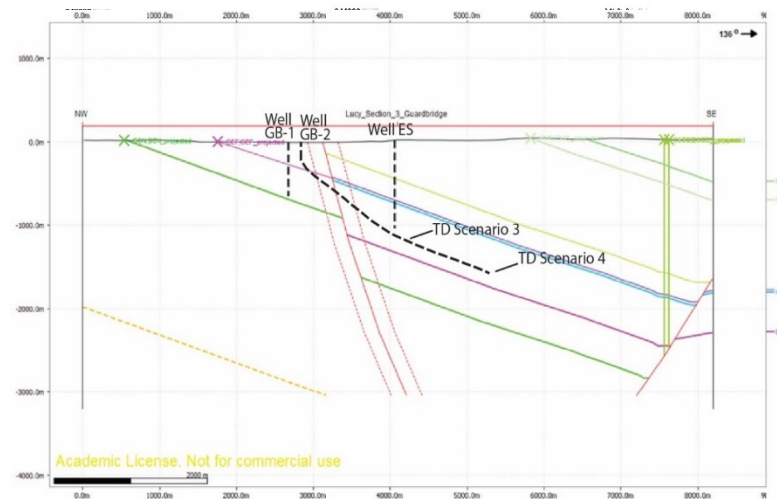

Line 2 – crude stacking, preliminary processing

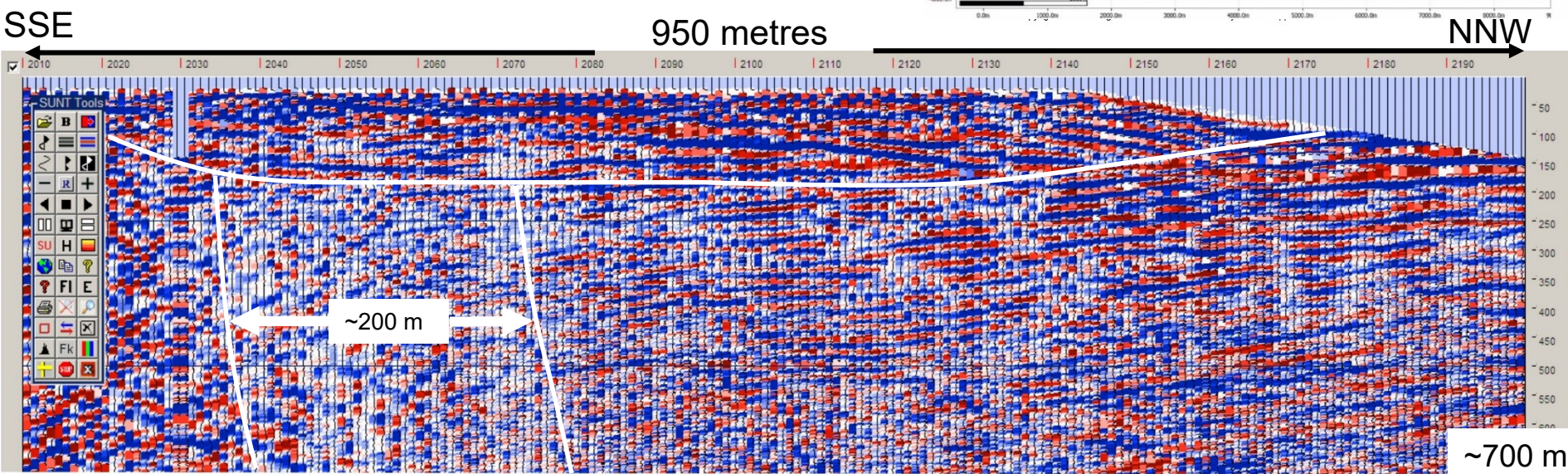



# Thanks to:



Ed Stephens



Richard Bates



Lucy McKay



Sarah Alexander

